



# BANCE



## PANDROL CLIP EXTRACTOR

- This product is the result of lengthy development undertaken to ensure exactly the right power for the job
- The two Bance Design Right tools have also been specially developed for the purpose

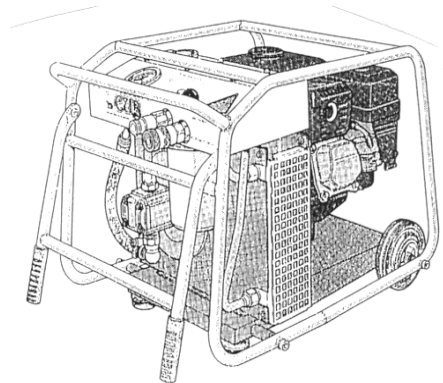
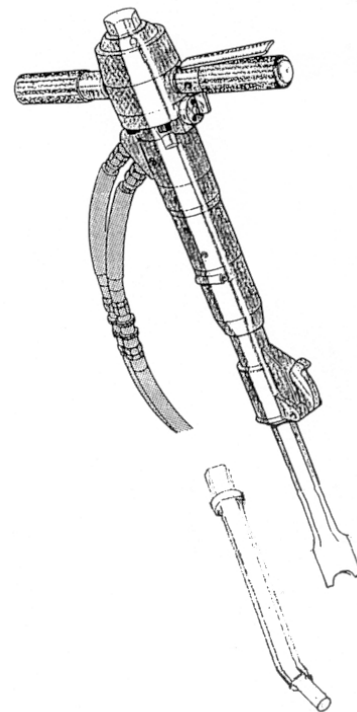

Tooling Copyright/Design Right is the property of R. Bance & Co. Ltd.

## **BANCE**

### **PCE Hydraulic Power Pack**

<u>Fuel:</u>	Petrol
<u>Engine:</u>	Honda GX160
<u>Power:</u>	5.5 HP (4 kw)
<u>Weight:</u>	37.5 kgs (82 lbs)
<u>Noise level:</u>	104 dB(A)
<u>Dimensions:</u>	L570 x W440 x H450 (23 x 18 x 18 in)

- Extremely portable
- Fitted with wheels
- Low hydraulic oil cut out – stops expensive damage to tools and pump
- Hydraulic oil level and filter condition gauges
- Rugged stainless steel frame construction

### **PCE Breaker**

<u>Vibration</u>	14.97m/sec <sup>2</sup> (49ft / sec <sup>2</sup> )
<u>Weight:</u>	18 kgs (40 lbs)
<u>Height:</u>	700 mm (27 ins)
<u>Noise level:</u>	108 dB(A)

- Complete with tail hoses
- Vibration dampened handles

### **PCE Steels**

#### **Two special Design Right steels for Pandrol Clip Extraction**

- Round point for driving out broken clips
- 'U' point for driving against the rounded section of clips